



swiss lifting solutions

# TECHNICAL DATA GIS - SLEWING JIB CRANES



since  
1957

[www.gis-ag.ch](http://www.gis-ag.ch)



## General information

General information	03
---------------------	----

## Pillar-mounted slewing jib cranes

Pillar-mounted slewing jib cranes GISKB steel hollow profile	04
Pillar-mounted slewing jib cranes GISKB aluminium hollow profile	05
Pillar-mounted slewing jib cranes GSD-TR steel pipe profile	06
Pillar-mounted slewing jib cranes IPE steel profile	07

## Wall-mounted slewing jib cranes

Wall-mounted slewing jib cranes GISKB steel hollow profile	08
Wall-mounted slewing jib cranes GISKB aluminium hollow profile	09
Wall-mounted slewing jib cranes GWD-TR steel pipe profile	10
Wall-mounted slewing jib cranes IPE steel profile	11

## Ceiling-mounted slewing jib cranes

Ceiling-mounted slewing jib cranes GISKB steel hollow profile	12
Ceiling-mounted slewing jib cranes GISKB aluminium hollow profile	12
Ceiling-mounted slewing jib cranes GSD-TR steel pipe profile	13
Ceiling-mounted slewing jib cranes IPE steel profile	13

## Mobile slewing jib cranes

Mobile pillar-mounted slewing jib cranes GISKB steel hollow profile	14
Mobile pillar-mounted slewing jib cranes GISKB aluminium hollow profile	15
Mobile pillar-mounted slewing jib cranes GSD-TR steel pipe profile	16
Mobile pillar-mounted slewing jib cranes IPE steel profile	17

## Miscellaneous

Energy supply	18
Composite technology	19
Special solutions	19

## SWISS LIFTING SOLUTION

GIS pillar- and wall-mounted slewing jib cranes offer a simple and functional solution for ergonomic goods handling. Depending on the desired load capacity, the jib working radius and the running properties, aluminium or steel profiles are used.

In combination with a GIS electric chain hoist and a trolley (manual or electric), a GIS vacuum-handling system or another load-handling device, you get a complete crane system from one source - directly from the Swiss manufacturer. GIS slewing cranes are a reasonable addition to a complete materials handling system. The all-purpose application is used for single-user workstations, storage areas, loading ramps or in halls, whenever other handling devices are not suitable due to static reasons.

GIS slewing cranes are differed in pillar- and wall- or ceiling-mounted slewing cranes. The second substantial difference is the crane rail. Depending on the construction conditions and the lifting capacities a GISKB profile, IPE steel profile or a square profile is used for the jib arm. The slewing cranes are optimised to the respective application.

Depending on customised requirements, special solutions can be offered. We revert to a vast range of accessoires.

GIS slewing cranes are designed in accordance with the latest EU Machinery Directive DIN15018.



# Slewing pillar crane GISKB steel hollow profile

Lifting capacity up to 1000 kg - according DIN 15018

## Standard version

Pillar and jib primed light grey RAL 7035  
 Slewing range up to 270° stepless (manually)  
 Trolley with smoothly running plastic load wheels  
 Traction limit for trolley  
 Without mounting material

## Options:

Coating upon request or hot-dip galvanised  
 Power supply; trailing cable, c-rail or conductor line with main switch (see page 18)  
 Electric moving  
 Mounting options can be found on page 19  
 Special solutions can be found on page 19  
 Construction heights and jib lengths can be adapted individually to customer's needs.  
 GIS electric chain hoist

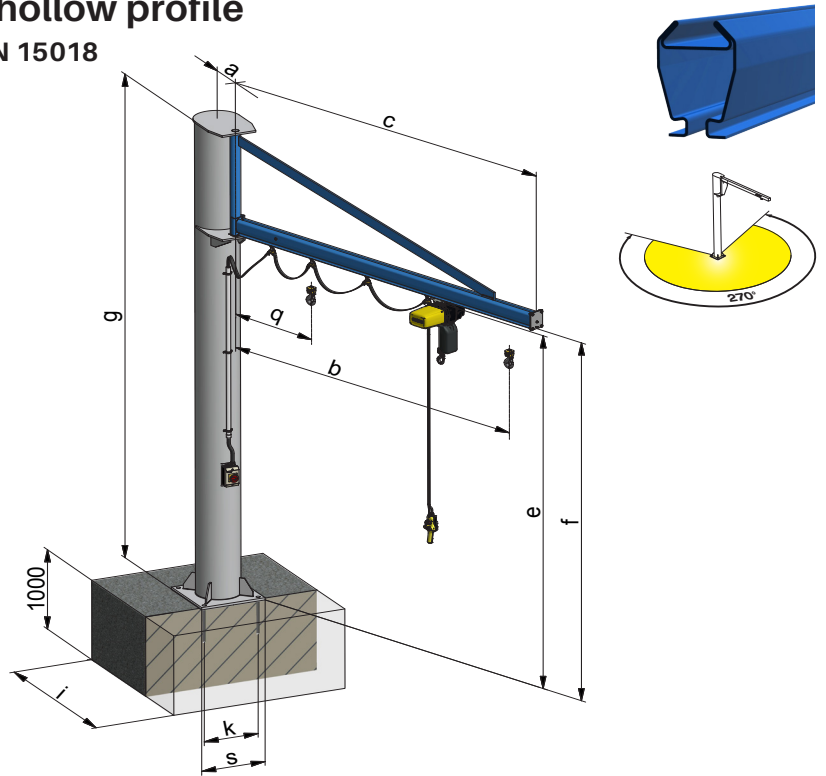

Part number	Capacity kg	Jib arm C mm	Construction height g mm	f mm	e mm	a mm	q mm	b mm	GISKB steel	Floor plate drill holes mm	k □mm	s □mm	Base i □mm	Pillar Ø mm
9311.1000/125/2	125	2000	3800	3303	3272	265	424	1890	I	4 × Ø20	300	400	800	273
9311.1001/125/3		3000					524	2890					950	
9311.1002/125/4		4000					624	3890					1050	
9311.1006/125/5	160	5000	4200	3300	3265	300	647	4879	II	4 × Ø30	425	500	1200	324
9311.1000/160/2		2000					424	1890					850	
9311.1001/160/3		3000					524	2890					1000	
9311.1002/160/4	4000	624	3890	1100										
9311.1006/160/5	5000	647	4879	1250										
9311.1003/200/2	200	2000	3800	3303	3265	265	424	1890	I	4 × Ø20	300	400	900	273
9311.1004/200/3		3000					524	2890					1050	
9311.1005/200/4		4000					647	3879					1150	
9311.1006/200/5	5000	647	4879	1300										
9311.1003/250/2	250	2000	3800	3300	3265	265	424	1890	I	4 × Ø20	300	400	950	273
9311.1004/250/3		3000					524	2890					1100	
9311.1005/250/4		4000					647	3879					1250	
9311.1006/250/5	5000	647	4879	1350										
9311.1003/320/2	320	2000	3800	3300	3265	265	424	1890	I	4 × Ø20	300	400	1000	273
9311.1004/320/3		3000					524	2890					1200	
9311.1005/320/4		4000					647	3879					1350	
9311.1006/320/5	5000	647	4879	1450										
9311.1007/400/2	400	2000	4200	3300	3265	300	424	1890	I	4 × Ø20	300	400	1100	273
9311.1008/400/3		3000					547	2879					1300	
9311.1009/400/4		4000					647	3879					1400	
9311.1010/400/5	5000	647	4879	1550										
9311.1007/500/2	500	2000	3800	3300	3265	265	424	1890	I	4 × Ø20	300	400	1200	273
9311.1008/500/3		3000					547	2879					1350	
9311.1009/500/4		4000					647	3879					1500	
9311.1010/500/5	5000	647	4879	1650										
9311.1011/630/2	630	2000	4200	3300	3265	300	447	1879	II	4 × Ø30	425	500	1300	324
9311.1008/630/3		3000					547	2879					1450	
9311.1009/630/4		4000					647	3879					1650	
9311.1014/630/5	5000	647	4879	1800										
9311.1011/800/2	800	2000	4200	3300	3265	300	447	1879	II	4 × Ø30	425	500	1400	324
9311.1012/800/3		3000					547	2879					1600	
9311.1013/800/4		4000					647	3879					1800	
9311.1014/800/5	5000	647	4879	1950										
9311.1015/1000/2	1000	2000	4200	3300	3265	350	447	1879	II	4 × Ø30	425	500	1450	324
9311.1016/1000/3		3000					547	2879					1700	
9311.1017/1000/4		4000					647	3879					1900	
9311.1018/1000/5	5000	647	4879	2050										



# Slewing pillar crane GISKB aluminium hollow profile

Lifting capacity up to 500 kg - according DIN 15018

## Standard version

- Pillar primed light grey RAL 7035
- Jib arm aluminium hollow profile
- Slewing range 270° stepless (manually)
- Trolley with smoothly running plastic load wheels
- Traction limit for trolley
- Without mounting material

## Options:

- Coating of pillar upon request or hot-dip galvanised
- Power supply; trailing cable, c-rail or conductor line with main switch (see page 18)
- Mounting options can be found on page 19
- Special solutions can be found on page 19
- Construction heights and jib lengths can be adapted individually to customer's needs.
- GIS electric chain hoist

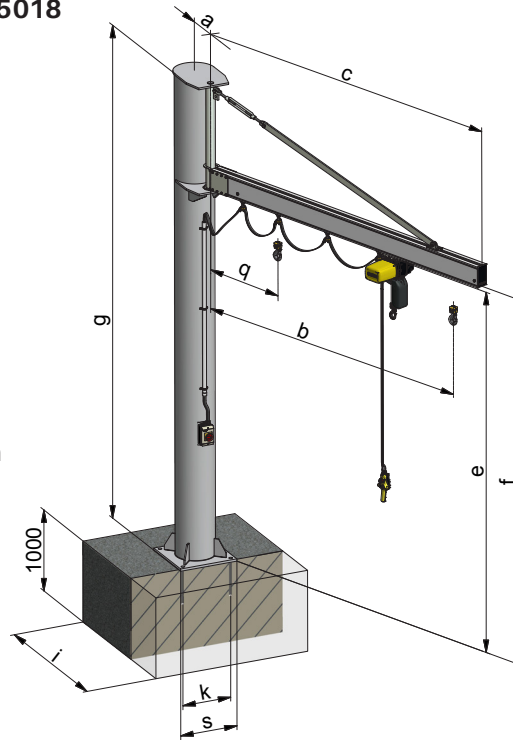

Part number	Capacity kg	Jib arm C mm	Construction height g mm	f mm	e mm	a mm	q mm	b mm	GISKB alum.	Floor plate drill holes mm	k □mm	s □mm	Base i □mm	Pillar Ø mm
9311.2000/125/2		2040					458	1885					800	
9311.2001/125/3		3040	3800			265	558	2885	M	4 × Ø20	300	400	950	273
9311.2003/125/4	125	4040		3300	3279		658	3885					1050	
9311.2006/125/5		5050	4200			300	668	4895	L	4 × Ø30	425	500	1200	324
9311.2008/125/6		6050					768	5895					1250	
9311.2000/160/2		2040					458	1885					850	
9311.2001/160/3		3040	3800			265	558	2885	M	4 × Ø20	300	400	1000	273
9311.2003/160/4	160	4040		3300	3279		658	3885					1100	
9311.2006/160/5		5050	4200			300	668	4895	L	4 × Ø30	425	500	1250	324
9311.2008/160/6		6050					768	5895					1300	
9311.2000/200/2		2040	3800			265	458	1885	M	4 × Ø20	300	400	900	273
9311.2001/200/3		3040					558	2885					1050	
9311.2004/200/4	200	4050		3300	3279		568	3895					1150	
9311.2006/200/5		5050	4200			300	668	4895	L	4 × Ø30	425	500	1300	324
9311.2008/200/6		6050					768	5895					1350	
9311.2000/250/2		2040	3800			265	458	1885	M	4 × Ø20	300	400	950	273
9311.2001/250/3		3040					558	2885					1100	
9311.2004/250/4	250	4050		3300	3279		568	3895					1250	324
9311.2006/250/5		5050	4200			300	668	4890	L	4 × Ø30	425	500	1350	
9311.2009/250/6		6050				350	768	5895		6 × Ø30	500	600	1400	407
9311.2000/320/2		2040	3800			265	458	1885	M	4 × Ø20	300	400	1000	273
9311.2001/320/3		3040					558	2885					1200	
9311.2004/320/4	320	4050		3300	3279		568	3895					1350	324
9311.2006/320/5		5050	4200			300	668	4895	L	4 × Ø30	425	500	1450	
9311.2009/320/6		6050				350	768	5895		6 × Ø30	500	600	1500	407
9311.2000/400/2		2040	3800			265	458	1885	M	4 × Ø20	300	400	1100	273
9311.2002/400/3		3050				300	468	2895		4 × Ø30	425	500	1300	324
9311.2005/400/4	400	4050	4200	3300	3279		568	3895	L				1400	
9311.2007/400/5		5050				350	668	4895		6 × Ø30	500	600	1550	407
9311.2009/400/6		6050					768	5895					1600	
9311.2000/500/2		2040	3800			265	458	1885	M	4 × Ø20	300	400	1200	273
9311.2002/500/3		3050				300	468	2895		4 × Ø30	425	500	1350	324
9311.2005/500/4	500	4050	4200	3300	3279		568	3895	L				1500	407
9311.2007/500/5		5050				350	668	4895		6 × Ø30	500	600	1650	
9311.2010/500/6		6050				450	768	5895		8 × Ø32	600	700	1700	508

# Articulated slewing pillar crane GSD-TR steel pipe profile

Lifting capacity up to 250 kg - according DIN 15018

## Standard version

Articulated pillar-mounted slewing jib crane with maximum slewing range  
 Suitable for excentric load handling with GIS handy telescope model  
 Slewing range up to 270° (inner), respectively up to 330° (outer)  
 Jib length 2.6 m, longer jibs on request

### Options:

Coating upon request or hot-dip galvanised  
 Power supply; trailing cable, c-rail or conductor line with main switch  
 with brake on internal and external joint  
 Mounting options can be found on page 19  
 Special solutions can be found on page 19  
 Construction height can be adapted to individual requirements.  
 GIS handy telescope model

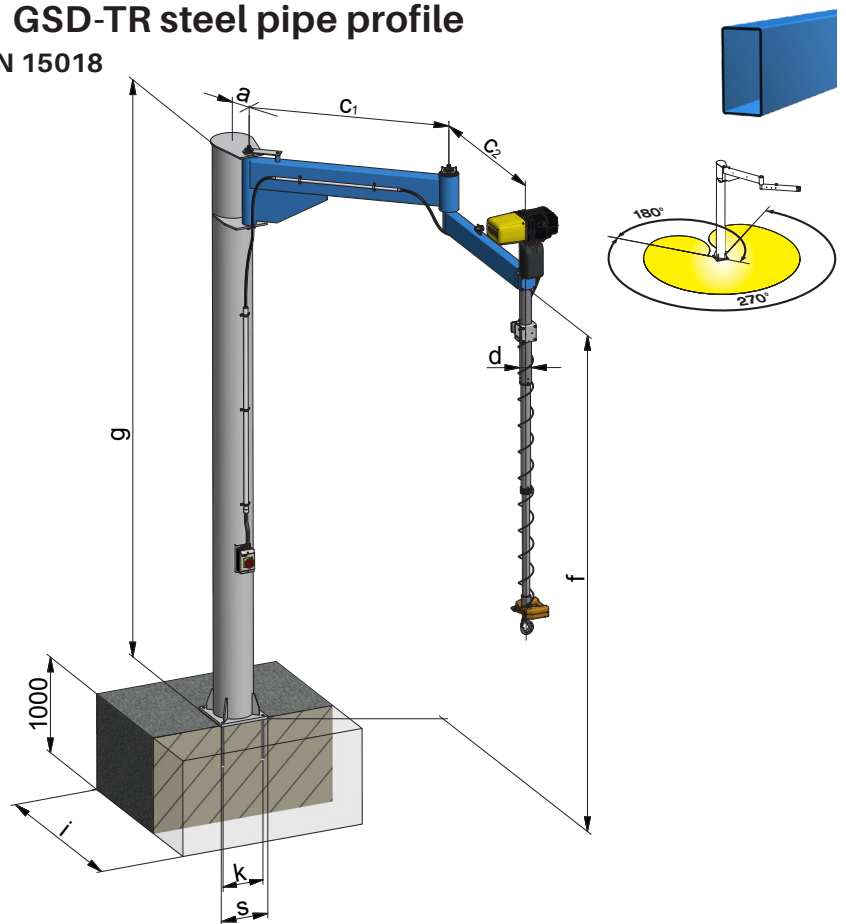

Part number	Capacity kg	Jib arm C1/C2 mm	a mm	Construction height g mm	BE jib arm f mm	k mm	s mm	i mm	Floor plate drill holes mm	d Ø mm	Pillar Ø mm
9311.3102.2	250	1400/1206	265	3400	2969	300	350	1200	4 × Ø20	80	273

# Slewing pillar crane IPE steel profile

## Lifting capacity up to 1000 kg - according DIN 15018

### Standard version

Pillar primed light grey RAL 7035  
 Jib IPE steel profile  
 Slewing range up to 270° stepless (manually)  
 Rubber buffers mounted to the end of the jib  
 Without mounting material

### Options:

Coating upon request or hot-dip galvanised  
 Power supply; trailing cable, c-rail or conductor line with main switch (see page 18)  
 Mounting options can be found on page 19  
 Special solutions can be found on page 19  
 Construction heights and jib lengths can be adapted to individual requirements.  
 GIS electric chain hoist with manual or motorised trolley

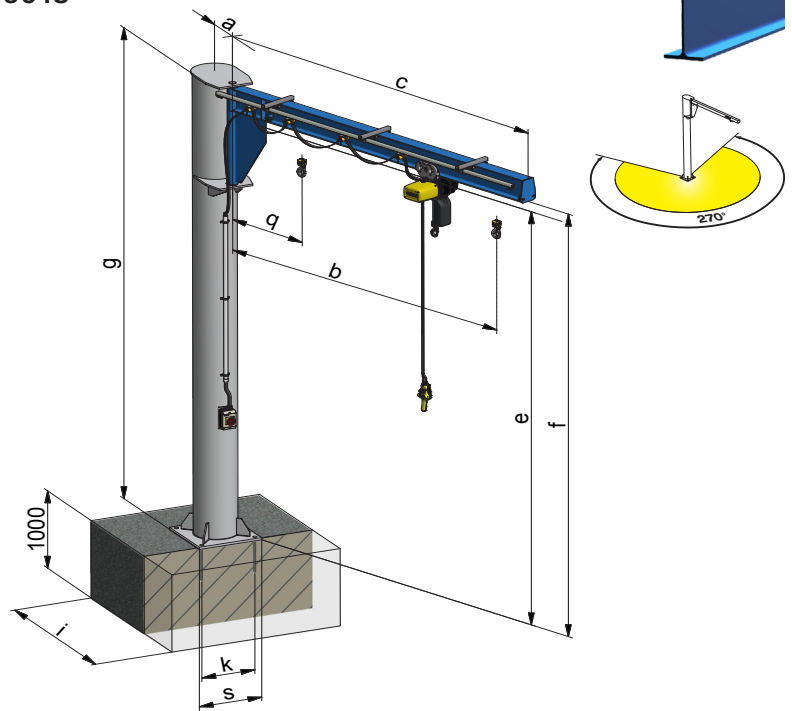

Capacity kg	Jib arm c mm	Construction height g mm	BE jib f mm	e mm	a mm	q mm	b mm	IPE	Flange mm	Floor plate drill holes mm	k □mm	s □mm	Base i □mm	Pillar Ø mm
125	2000	3800	3612	3571	265	482	1860	160	82	4 × Ø20	300	400	950	273
	3000						2860							
	4000						3860							
	5000						4860							
160	2000	3800	3592	3552	265	482	1860	180	91	4 × Ø20	300	400	1000	273
	3000						2860							
	4000						3860							
	5000						4860							
200	2000	3800	3612	3571	265	482	1860	180	91	4 × Ø20	300	400	1050	273
	3000						2860							
	4000						3860							
	5000						4860							
250	2000	3800	3592	3552	265	482	1860	180	91	4 × Ø20	300	400	1100	273
	3000						2860							
	4000						3860							
	5000						4860							
320	2000	3800	3612	3571	265	482	1860	200	100	4 × Ø20	300	400	1200	273
	3000						2860							
	4000						3860							
	5000						4860							
400	2000	3800	3612	3571	265	482	1860	160	82	4 × Ø20	300	400	1100	273
	3000						2860							
	4000						3860							
	5000						4860							
500	2000	3800	3592	3552	265	482	1860	180	91	4 × Ø20	300	400	1200	273
	3000						2860							
	4000						3860							
	5000						4860							
630	2000	4200	3992	3952	300	482	1860	180	91	4 × Ø30	425	500	1300	324
	3000						2860							
	4000						3860							
	5000						4860							
800	2000	4200	3972	3932	300	537	1860	200	100	4 × Ø30	425	500	1400	324
	3000						2860							
	4000						3860							
	5000						4860							
1000	2000	4200	3972	3932	350	546	1860	240	120	4 × Ø30	425	500	1450	324
	3000						2860							
	4000						3860							
	5000						4860							

# Slewing wall crane GISKB steel hollow profile

Lifting capacity up to 1000 kg - according DIN 15018

## Standard version

Console and jib arm primed light grey RAL 7035  
 Slewing range 180°/ 270° stepless (manually)  
 Trolley with smoothly running plastic load wheels  
 Travel limit stop for trolley  
 Without mounting material

## Options:

Coating upon request or hot-dip galvanised  
 Power supply; trailing cable, c-rail or conductor line with main switch (see page 18)  
 Electric travel movements  
 Mounting options can be found on page 19  
 Special solutions can be found on page 19  
 Construction heights and jib arm length can be adapted to customer's requirements.  
 GIS electric chain hoist

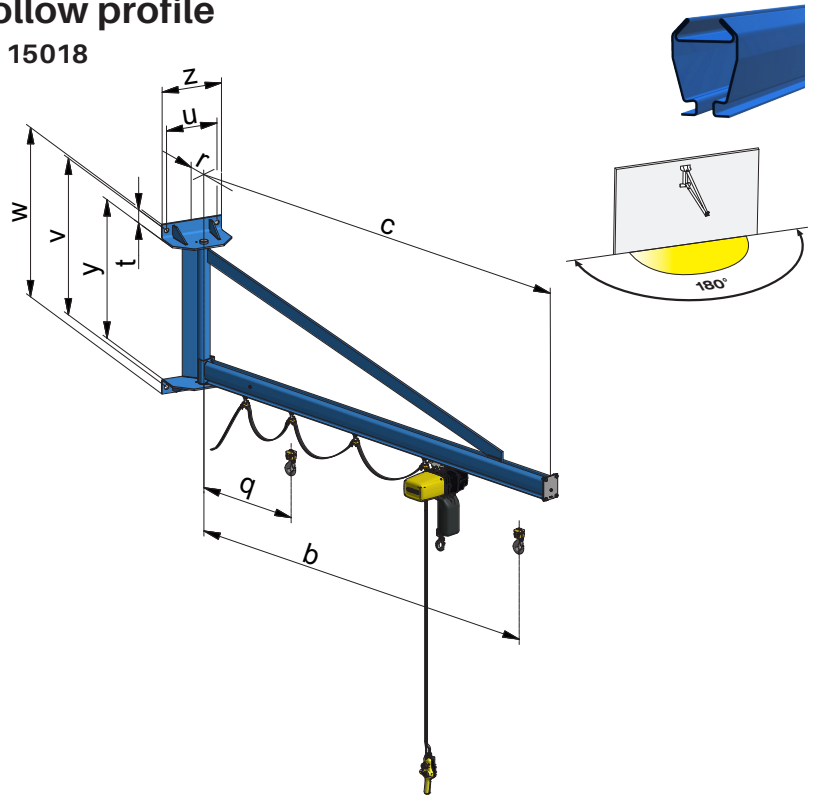

Part number	Capacity kg	Jib arm c mm	u mm	v mm	w mm	y mm	z mm	r mm	b mm	q mm	t mm	GISKB	Console drill holes mm
9311.1019/125/2	125	2000	240	619	701	501	300	160	1890	424	59	I	4 × Ø27
9311.1020/125/3		3000							2890	524			
9311.1021/125/4		4000							3890	624			
9311.1025/125/5		5000							4879	647			
9311.1019/160/2	160	2000	240	619	701	501	300	160	1890	424	59	I	4 × Ø27
9311.1020/160/3		3000							2890	524			
9311.1021/160/4		4000							3890	624			
9311.1025/160/5		5000							4879	647			
9311.1022/200/2	200	2000	240	619	701	501	300	160	1890	424	59	I	4 × Ø27
9311.1023/200/3		3000							2890	524			
9311.1024/200/4		4000							3879	647			
9311.1025/200/5		5000							4879				
9311.1022/250/2	250	2000	240	619	701	501	300	160	1890	424	59	I	4 × Ø27
9311.1023/250/3		3000							2890	524			
9311.1024/250/4		4000							3879	647			
9311.1025/250/5		5000							4879				
9311.1022/320/2	320	2000	265	619	701	501	300	160	1890	424	59	I	4 × Ø27
9311.1023/320/3		3000							2890	524			
9311.1024/320/4		4000							3879	647			
9311.1025/320/5		5000							4879				
9311.1026/400/2	400	2000	240	619	701	501	300	160	1770	424	59	I	4 × Ø27
9311.1027/400/3		3000							2879	547			
9311.1028/400/4		4000							3879	647			
9311.1029/400/5		5000							4879				
9311.1026/500/2	500	2000	240	619	701	501	300	160	1770	424	59	I	4 × Ø27
9311.1027/500/3		3000							2879	547			
9311.1028/500/4		4000							3879	647			
9311.1029/500/5		5000							4879				
9311.1030/630/2	630	2000	340	1019	1101	901	400	185	1879	447	59	II	4 × Ø30
9311.1027/630/3		3000							2879	547			
9311.1028/630/4		4000							3879	647			
9311.1033/630/5		5000							4879				
9311.1030/800/2	800	2000	340	1019	1101	901	400	185	1879	447	59	II	4 × Ø30
9311.1031/800/3		3000							2879	547			
9311.1032/800/4		4000							3879	647			
9311.1033/800/5		5000							4879				
9311.1034/1000/2	1000	2000	340	1019	1101	901	400	185	1879	447	59	II	4 × Ø30
9311.1035/1000/3		3000							2879	547			
9311.1036/1000/4		4000							3879	647			
9311.1037/1000/5		5000							4879				



# Slewing wall crane GISKB aluminium hollow profile

Lifting capacity up to 500 kg - according DIN 15018

## Standard version

Console primed light grey RAL 7035  
 Aluminium profile jib arm  
 Slewing range 180° / 270° stepless (manually)  
 Trolley with smoothly running plastic load wheels  
 Travel limit stop for trolley  
 Without mounting material

## Options:

Coating of console upon request or hot-dip galvanised  
 Power supply; trailing cable, c-rail or conductor line with main switch (see page 18)  
 Mounting options can be found on page 19  
 Special solutions can be found on page 19  
 Construction heights and jib arm length can be adapted to customer's requirements.  
 GIS electric chain hoist

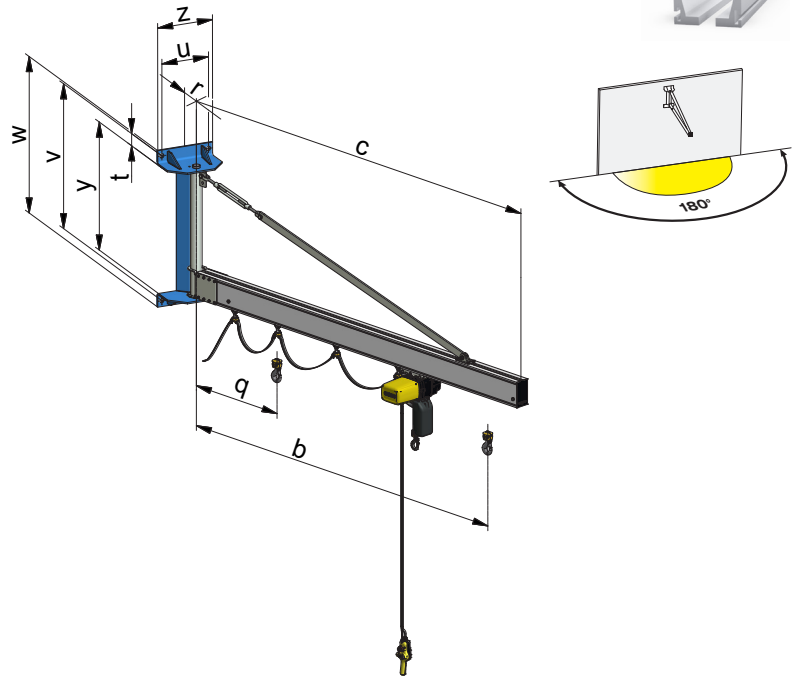

Part number	Capacity kg	Jib arm C mm	u mm	v mm	w mm	y mm	z mm	r mm	b mm	q mm	t mm	GISKB aluminium	Console drill holes mm
9311.2020/125/2	125	2040	240	619	701	501	300	160	1885	458	59	M	4 × Ø27
9311.2021/125/3		3040							2885	558			
9311.2023/125/4		4040							3885	658			
9311.2025/125/5		5050	340	1019	1101	901	400	185	4895	668		L	4 × Ø30
9311.2026/125/6		6050							5895	768			
9311.2020/160/2		2040							1885	458			
9311.2021/160/3	3040	240	619	701	501	300	160	2885	558	59	M	4 × Ø27	
9311.2023/160/4	4040	3885	658										
9311.2025/160/5	5050	340	1019	1101	901	400	185	4895	668				L
9311.2026/160/6	6050							5895	768				
9311.2020/200/2	2040							1885	458				
9311.2021/200/3	3040	240	619	701	501	300	160	2885	558		59	M	4 × Ø27
9311.2024/200/4	4050	3895	568										
9311.2025/200/5	5050	340	1019	1101	901	400	185	4895	668	L			
9311.2026/200/6	6050							5895	768				
9311.2020/250/2	2040							1885	458				
9311.2021/250/3	3040	240	619	701	501	300	160	2885	558	59		M	4 × Ø27
9311.2024/250/4	4050	3895	568										
9311.2025/250/5	5050	340	1019	1101	901	400	185	4895	668		L		
9311.2026/250/6	6050							5895	768				
9311.2020/320/2	2040							1885	458				
9311.2022/320/3	3040	240	619	701	501	300	160	2885	558		59	M	4 × Ø27
9311.2024/320/4	4050	3895	568										
9311.2025/320/5	5050	340	1019	1101	901	400	185	4895	668	L			
9311.2026/320/6	6050							5895	768				
9311.2020/400/2	2040							1885	458				
9311.2022/400/3	3050	240	619	701	501	300	160	2895	468	59		M	4 × Ø27
9311.2024/400/4	4050	3895	568										
9311.2025/400/5	5050	340	1019	1101	901	400	185	4895	668		L		
9311.2026/400/6	6050							5895	768				
9311.2020/500/2	2040							1885	458				
9311.2022/500/3	3050	240	619	701	501	300	160	2895	468		59	M	4 × Ø27
9311.2024/500/4	4050	3895	568										
9311.2025/500/5	5050	340	1019	1101	901	400	185	4895	668	L			
9311.2026/500/6	6050							5895	768				

# Slewing wall crane GWD-TR steel pipe profile

Lifting capacity up to 250 kg - according DIN 15018

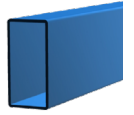

## Standard version

Pillar and jib primed light grey RAL 7035  
 Slewing range 270° / 180° stepless (manually)  
 Without mounting material

### Options:

Coating upon request or hot-dip galvanised  
 Power supply with main switch  
 Mounting options can be found on page 19  
 Special solutions can be found on page 19  
 Construction height can be adapted to customer's requirements.  
 GIS handy telescope model

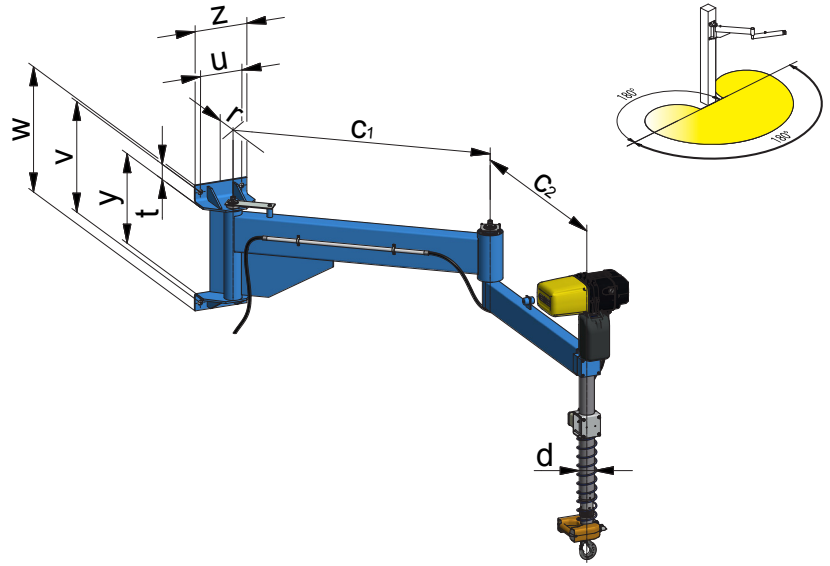

Part number	Capacity kg	Jib arm C1/C2 mm	r mm	z mm	u mm	w mm	v mm	y mm	t mm	Console drill holes mm	d Ø mm
9311.3103.2	250	1400/1206	160	300	240	701	619	501	59	4 × Ø27	80

# Slewing wall crane IPE steel profile

Lifting capacity up to 1000 kg - according DIN 15018

## Standard version

Console and jib arm primed light grey RAL 7035  
 Slewing range 180°/ 270° stepless (manually)  
 Rubber buffers mounted to the end of the jib  
 Without mounting material

### Options:

Coating upon request or hot-dip galvanised  
 Power supply; trailing cable, c-rail or conductor line with main switch (see page 18)  
 Mounting options can be found on page 19  
 Special solutions can be found on page 19  
 Construction heights and jib arm length can be adapted to customer's requirements.  
 GIS electric chain hoist with manual or motorised trolley

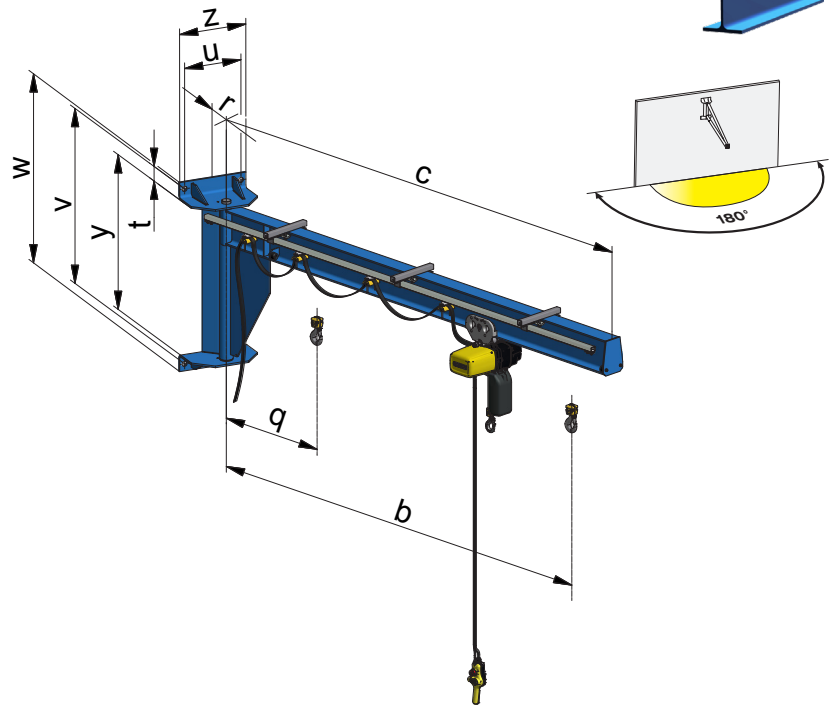

Capacity kg	Jib arm c mm	u mm	v mm	w mm	y mm	z mm	r mm	b mm	q mm	t mm	IPE	Flange mm	Console drill holes mm	
125	2000	240	619	701	501	300	160	1860	482	59	160	82	4 × Ø27	
	3000							2860						
	4000							3860						
	5000							4860						4 × Ø30
160	2000	240	619	701	501	300	160	1860	482	59	160	82	4 × Ø27	
	3000							2860			180	91		
	4000							3860			240	120		4 × Ø30
	5000							4860			546	240		120
200	2000	240	619	701	501	300	160	1860	482	59	160	82	4 × Ø27	
	3000							2890			180	91		
	4000							3860			240	120		4 × Ø30
	5000							4860			546	240		120
250	2000	240	619	701	501	300	160	1860	482	59	160	82	4 × Ø27	
	3000							2860			180	91		
	4000							3860			200	100		4 × Ø30
	5000							4860			546	240		120
320	2000	240	619	701	501	300	160	1860	537	59	160	82	4 × Ø27	
	3000							2860			200	100		
	4000							3860			220	110		4 × Ø30
	5000							4860			546	240		120
400	2000	240	619	701	501	300	160	1860	482	59	160	82	4 × Ø27	
	3000							2860			200	100		
	4000							3860			200	100		4 × Ø30
	5000							4860			603	300		150
500	2000	340	1019	1101	901	400	185	1860	482	59	180	91	4 × Ø27	
	3000							2860			200	100		
	4000							3860			220	110		4 × Ø30
	5000							4860			603	300		150
630	2000	340	1019	1101	901	400	185	1860	537	59	180	91	4 × Ø30	
	3000							2860			200	100		
	4000							3860			240	120		4 × Ø30
	5000							4860			603	300		150
800	2000	340	1019	1101	901	400	185	1860	546	59	200	100	4 × Ø30	
	3000							2860			220	110		
	4000							3860			300	150		
	5000							4860			603	300		150
1000	2000	340	1019	1101	901	400	185	1860	546	59	240	120	4 × Ø30	
	3000							2860			300	150		
	4000							3860			300	150		
	5000							4860			603	330		160

## Ceiling-mounted slewing jib crane GISKB steel hollow profile

Lifting capacity up to 1000 kg - according DIN 15018

### Execution available optionally

Pillar and jib primed light grey RAL 7035  
Slewing range 270° stepless (manually)  
Trolley with smoothly running plastic load wheels  
Travel limit stop for trolley  
Without mounting material

### Options:

Coating upon request or hot-dip galvanised  
Power supply; trailing cable, c-rail or conductor line with main switch (see page 18)  
Mounting options can be found on page 19  
Special solutions can be found on page 19  
Construction heights and jib arm length can be adapted to customer's requirements.  
GIS electric chain hoist

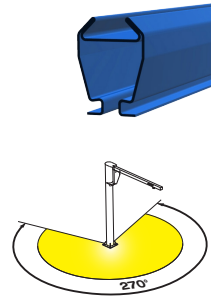
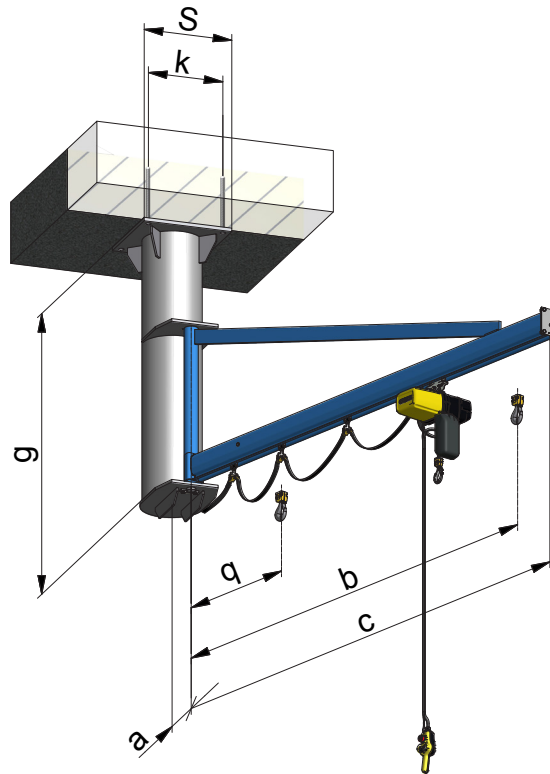

## Ceiling-mounted slewing jib crane GISKB aluminium hollow profile

Lifting capacity up to 500 kg - according DIN 15018

### Execution available optionally

Pillar primed light grey RAL 7035  
Aluminium profile jib arm  
Slewing range 270° stepless (manually)  
Trolley with smoothly running plastic load wheels  
Travel limit stop for trolley  
Without mounting material

### Options:

Coating of pillar upon request or hot-dip galvanised  
Power supply; trailing cable, c-rail or conductor line with main switch (see page 18)  
Mounting options can be found on page 19  
Special solutions can be found on page 19  
Construction heights and jib arm length can be adapted to customer's requirements.  
GIS electric chain hoist

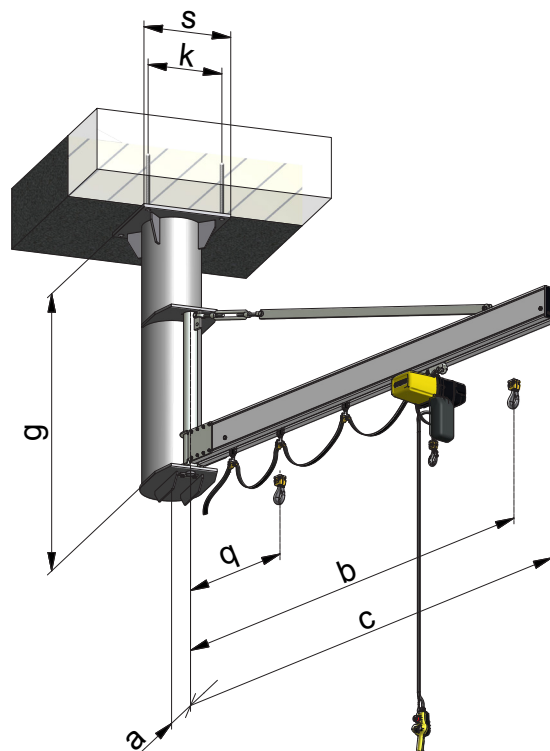

## Articulated ceiling-mounted slewing crane GSD-TR steel pipe profile

Lifting capacity up to 250 kg - according DIN 15018

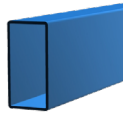

### Execution available optionally

Pillar and jib primed light grey RAL 7035  
Slewing range 270° / 180° stepless (manually)  
Without mounting material

#### Options:

Coating upon request or hot-dip galvanised  
Power supply with main switch  
Mounting options can be found on page 19  
Special solutions can be found on page 19  
Construction height can be adapted to customer's requirements.  
GIS handy telescope model

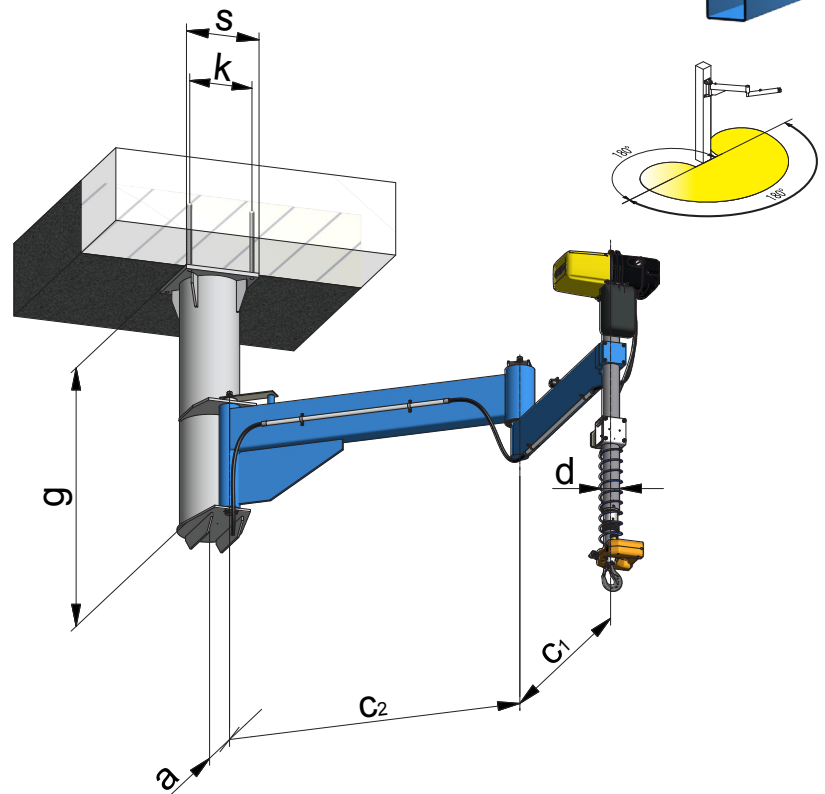

## Ceiling-mounted slewing jib crane IPE steel profile

Lifting capacity up to 1000 kg - according DIN 15018

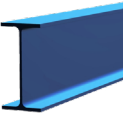

### Execution available optionally

Pillar primed light grey RAL 7035  
IPE steel profile jib arm  
Slewing range 270° stepless (manually)  
Rubber buffers mounted to the end of the jib  
Without mounting material

#### Options:

Coating of pillar upon request or hot-dip galvanised  
Power supply; trailing cable, c-rail or conductor line with main switch (see page 18)  
Mounting options can be found on page 19  
Special solutions can be found on page 19  
Construction heights and jib arm length can be adapted to customer's requirements.  
GIS electric chain hoist with manual or motorised trolley

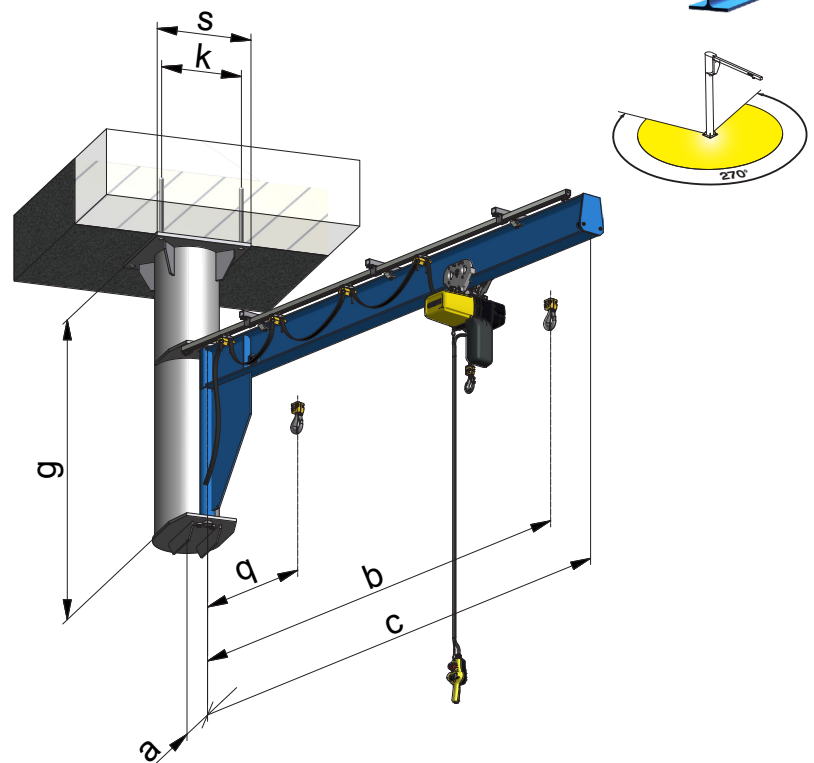



# Mobile slewing pillar cranes GISKB steel hollow profile

Lifting capacity up to 400 kg - according DIN 15018

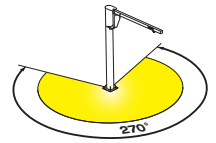
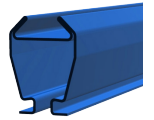

## Standard version

Pillar and jib primed light grey RAL 7035  
 Slewing range 270° stepless (manually)  
 Trolley with smoothly running plastic load wheels  
 Travel limit stop for trolley  
 including mounting material to concrete base

## Options:

Coating upon request or hot-dip galvanised  
 Power supply; trailing cable, c-rail or conductor line  
 with main switch (see page 18)  
 Mounting options can be found on page 19  
 Special solutions can be found on page 19  
 Construction heights and jib arm length can be  
 adapted to customer's requirements.  
 GIS electric chain hoist

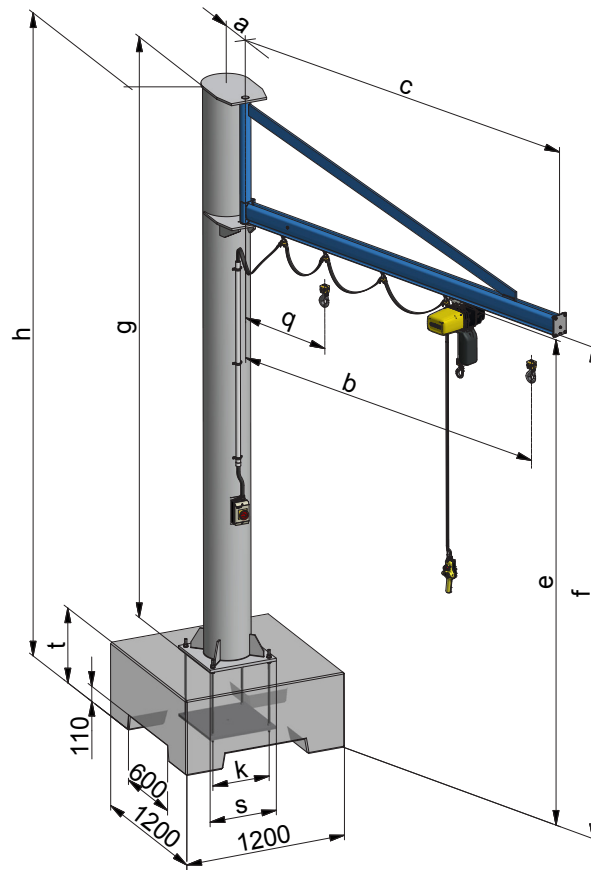

Capacity kg	Jib arm C mm	g mm	h mm	a mm	q mm	b mm	e mm	f mm	GISKB	Floor plate drill holes mm	k mm	s mm	Pillar Ø mm	t mm	Total weight kg	Floor loading kg/m <sup>2</sup>			
80	2000	3800	4160	265	424	1890	3632	3663	I	4 × Ø20	300	400	273	330	~1100	~770			
	3000				524	2890									~1125	~795			
	4000				624	3890									~1150	~820			
100	2000	3800	4160	265	424	1890	3632	3663	I	4 × Ø20	300	400	273	330	~1100	~790			
	3000				524	2890									~1125	~815			
	4000				624	3890									~1150	~840			
125	2000	3800	4160	265	424	1890	3632	3663	I	4 × Ø20	300	400	273	330	~1100	~800			
	3000		524		2890	~1125									~825				
	4000		4380		624	3880									3852	3883	550	~1900	~1320
160	2000	3800	4160	265	424	1890	3632	3663	I	4 × Ø20	300	400	273	330	~1100	~770			
	3000		4380		524	2890									3852	3883	550	~1900	~1320
	2000		4160		424	1890									3632	3663	330	~1100	~770
200	3000	3800	4380	265	524	2890	3852	3883	I	4 × Ø20	300	400	273	330	~1100	~770			
	2000		4160		424	1890									3632	3663	550	~1900	~1320
250	2000	3800	4160	265	424	1890	3632	3663	I	4 × Ø20	300	400	273	330	~1100	~770			
320	2000	3800	4160	265	424	1890	3632	3663	I	4 × Ø20	300	400	273	330	~1100	~770			
400	2000	3800	4160	265	424	1890	3852	3883	I	4 × Ø20	300	400	273	550	~1900	~1320			

# Mobile slewing pillar cranes GISKB aluminium hollow profile

Lifting capacity up to 400 kg - according DIN 15018

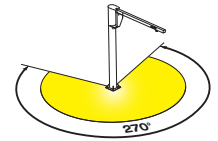
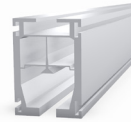

## Standard version

- Pillar primed light grey RAL 7035
- Aluminium profile jib arm
- Slewing range 270° stepless (manually)
- Trolley with smoothly running plastic load wheels
- Travel limit stop for trolley including mounting material to concrete base

## Options:

- Coating of pillar upon request or hot-dip galvanised
- Power supply; trailing cable, c-rail or conductor line with main switch (see page 18)
- Mounting options can be found on page 19
- Special solutions can be found on page 19
- Construction heights and jib arm length can be adapted to customer's requirements.
- GIS electric chain hoist

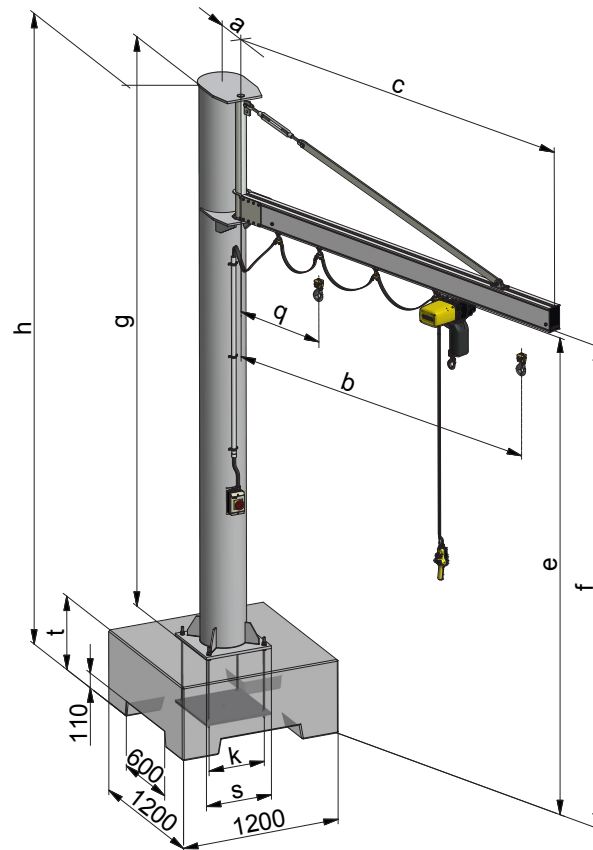

Capacity kg	Jib arm C mm	g mm	h mm	a mm	q mm	b mm	e mm	f mm	GISKB aluminium	Floor plate drill holes mm	k mm	s mm	Pillar Ø mm	t mm	Total weight kg	Floor loading kg/m <sup>2</sup>			
80	2040	3800	4160	265	458	1885	3639	3660	M	4 × Ø20	300	400	273	330	~1100	~770			
	3040				558	2885									~1125	~795			
	4040				658	3885									~1150	~820			
100	2040	3800	4160	265	458	1885	3639	3660	M	4 × Ø20	300	400	273	330	~1100	~790			
	3040				558	2885									~1125	~815			
	4040				658	3885									~1150	~840			
125	2040	3800	4160	265	458	1885	3639	3660	M	4 × Ø20	300	400	273	330	~1100	~800			
	3040		558		2885	~1125									~825				
	4040		4380		658	3885									3859	3880	550	~1900	~1320
160	2040	3800	4160	265	458	1885	3639	3660	M	4 × Ø20	300	400	273	330	~1100	~770			
	3040		4380		558	2885									3859	3880	550	~1125	~825
	2040		4160		458	1885									3639	3660	330	~1100	~770
200	3040	3800	4380	265	558	2885	3859	3880	M	4 × Ø20	300	400	273	330	~1100	~770			
	2040		4160		458	1885									3639	3660	550	~1900	~1320
250	2040	3800	4160	265	458	1885	3639	3660	M	4 × Ø20	300	400	273	330	~1100	~770			
320	2040	3800	4160	265	458	1885	3639	3660	M	4 × Ø20	300	400	273	330	~1100	~770			
400	2040	3800	4380	265	458	1885	3859	3880	M	4 × Ø20	300	400	273	550	~1900	~1320			

# Mobile articulated slewing pillar crane GSD-TR steel pipe profile

Lifting capacity up to 250 kg - according DIN 15018

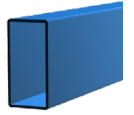

## Standard version

Pillar and jib primed light grey RAL 7035  
Slewing range 270° / 180° stepless (manually)

### Options:

Coating upon request or hot-dip galvanised  
Power supply with main switch  
Further options can be found on page 19  
Special solutions can be found on page 19  
Construction height can be adapted to customer's requirements.  
GIS handy telescope model

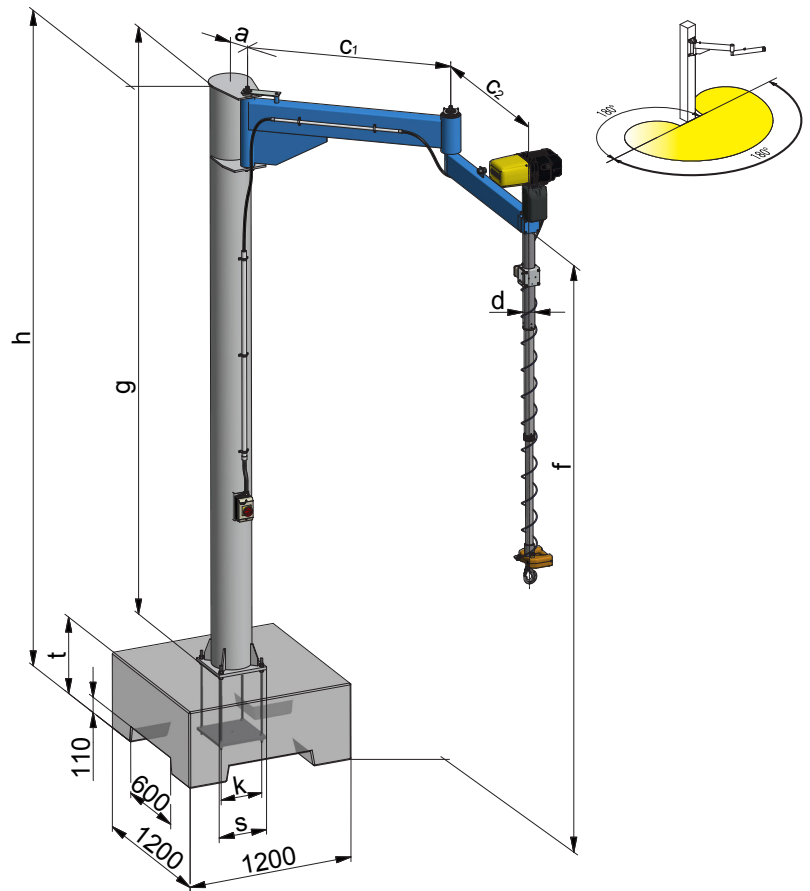

Capacity kg	Jib arm C1/C2 mm	Construc- tion height		BE jib arm f mm	k mm	s mm	t mm	h mm	Floor plate drill holes mm	d Ø mm	Pillar Ø mm
		a mm	g mm								
250	1400/1206	265	3400	2971	300	350	550	3950	4 × Ø20	80	273

# Mobile slewing pillar crane IPE steel profile

Lifting capacity up to 400 kg - according DIN 15018

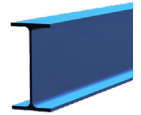

## Standard version

Pillar and jib primed light grey RAL 7035  
 Jib IPE steel profile  
 Slewing range 270° stepless (manually)  
 Rubber buffers mounted to the end of the jib including mounting material to concrete base

### Options:

Coating of pillar upon request or hot-dip galvanised  
 Power supply; trailing cable, c-rail or conductor line with main switch (see page 18)  
 Further options can be found on page 19  
 Special solutions can be found on page 19  
 Construction heights and jib arm length can be adapted to customer's requirements.  
 GIS GIS electric chain hoist with manual or motorised trolley

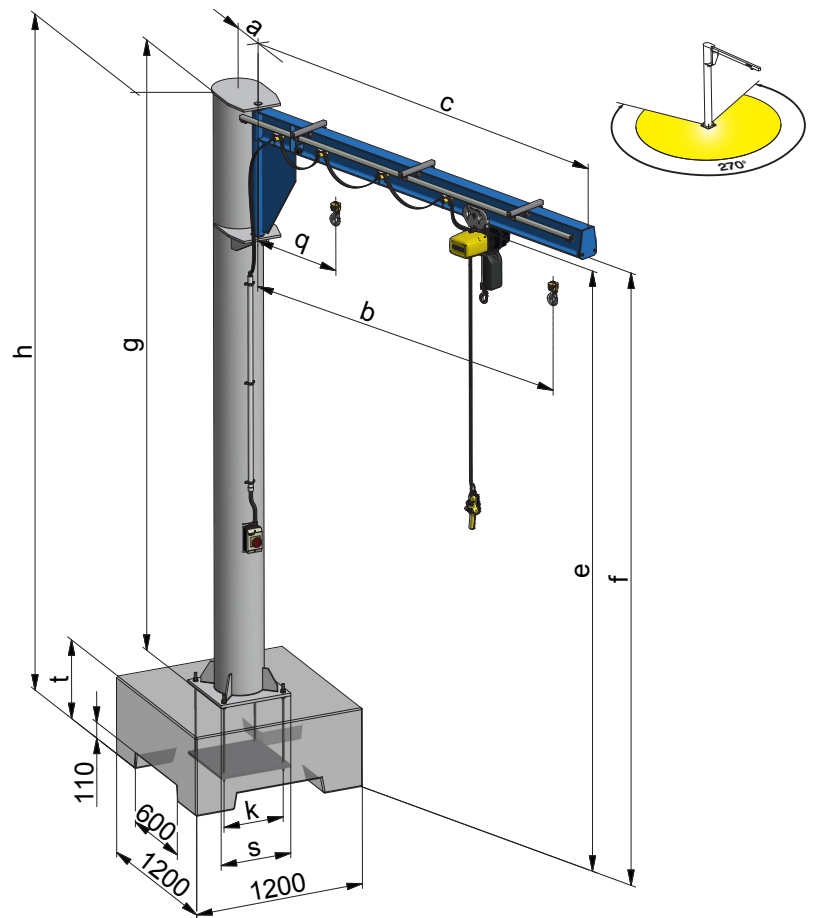

Capacity kg	C mm	g mm	h mm	a mm	q mm	b mm	e	f	IPE	Flange	k □mm	s □mm	Pillar Ø mm	t	Total weight kg	Floor loading kg/m <sup>2</sup>					
80	2000	3800	4160	265	482	1860	3931	3972	160	82	300	400	273	330	~1100	~770					
	3000					2860									~1125	~795					
	4000					3860									~1150	~820					
100	2000	3800	4160	265	482	1860	3931	3972	160	82	300	400	273	330	~1100	~790					
	3000					2860									~1125	~815					
	4000					3860									~1150	~840					
125	2000	3800	4160	265	482	1860	3931	3972	160	82	300	400	273	330	~1100	~800					
	3000		4380			2860									4151	4192	~1125	~825			
	4000		4380			3860									4151	4192	~1900	~1320			
160	2000	3800	4160	265	482	1860	3931	3972	160	82	300	400	273	330	~1100	~770					
	3000		4380			2860									4132	4192	180	91	550	~1900	~1320
	4000		4380			3860									4132	4192	180	91	550	~1900	~1320
200	2000	3800	4160	265	482	1860	3931	3972	160	82	300	400	273	330	~1100	~770					
	3000		4380			2860									4132	4192	180	91	550	~1900	~1320
	4000		4380			3860									4132	4192	180	91	550	~1900	~1320
250	2000	3800	4160	265	482	1860	3931	3972	160	82	300	400	273	330	~1100	~770					
320	2000	3800	4160	265	482	1860	3931	3972	160	82	300	400	273	330	~1100	~770					
400	2000	3800	4380	265	482	1860	4132	4192	160	82	300	400	273	550	~1900	~1320					

# Power supply

## Trailing cable GISKB

### Standard version

- Cable carriage trolley inside profile
- For contaminated or humid environment
- Cost-efficient solution
- Suitable for outdoor use
- With main switch
- Option: equipped with compressed-air supply

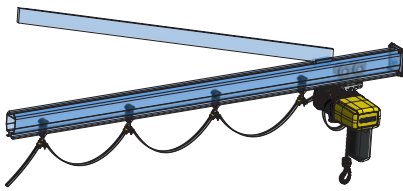

## C-rail GISKB

### With trailing cable

- For contaminated or humid environment
- Using the entire travel range
- Suitable for outdoor use
- With main switch
- Option: equipped with compressed-air supply

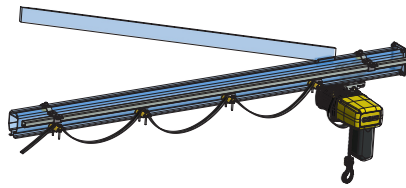

## Conductor line GISKB

### External

- Space-saving (no hanging cables)
- Ideal approach dimensions
- Aesthetic solution
- With main switch
- Option: available with internal conductor line

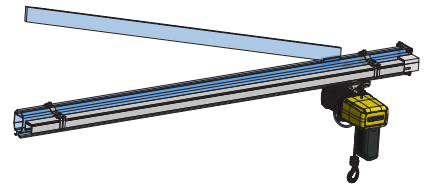

## Trailing cable IPE

### Standard version

- Cable carriage trolley moving on profile
- For contaminated or humid environment
- Cost-efficient solution
- Suitable for outdoor use
- With main switch
- Option: equipped with compressed-air supply

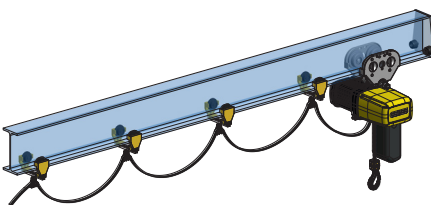

## C-rail IPE

### With trailing cable

- For contaminated or humid environment
- Using the entire travel range
- Suitable for outdoor use
- With main switch
- Option: equipped with compressed-air supply

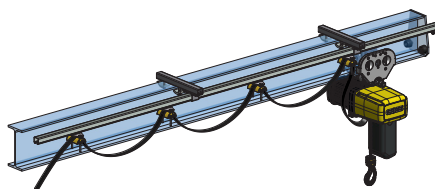

## Conductor line IPE

### External

- Space-saving (no hanging cables)
- Ideal approach dimensions
- Aesthetic solution
- With main switch

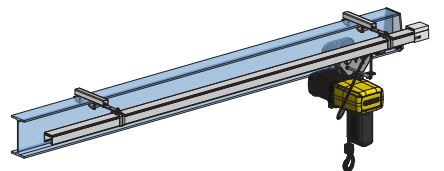



## Composite technology

The anchoring or dowelling technique is perfectly suitable for resilient concrete floors, walls or ceilings.

## Clasp

Ideal approach to the solution in case of concrete or steel pillars: frontally or around corners

## Counter plate

Distributes the force transmission in «sandwich»-load shared on a larger surface.

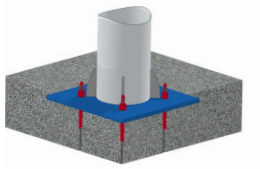

Anchoring technique for floor mounting

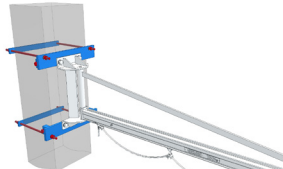

Classic clasp on frontal, rectangular pillar shape

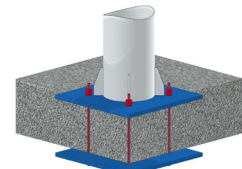

Floor plate for floor mounting

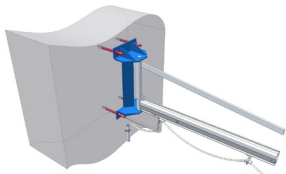

Dowelling technique for wall and ceiling mounting

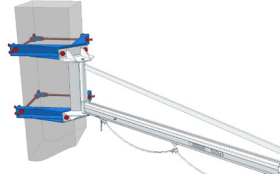

Fastening around corners

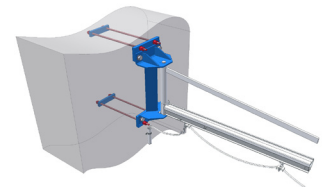

Wall mounting

## Special solutions

---

Higher lifting capacities up to 5000 kg

---

Electric slewing motion

---

Radio remote control for hoist and trolley

---

Frequency controlled hoist and trolley

---

Roving pendant, control switch independent of chain hoist

---

Slewing crane and chain hoists for outdoor use

---

Storm brake

---

Slewing limits

---

Special jib arm lengths

---

Double jib arm on a single pillar

---

Special pillar heights

---

Manual chain hoist

---

Console crane

---

Corrosion resistant version (food industry)

---

Jib arm with additional telescopic jib arm

---

Protection cover for chain hoist

---

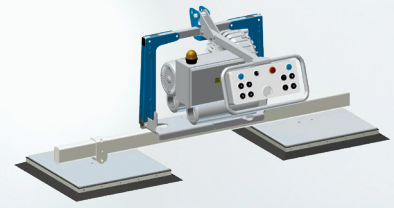
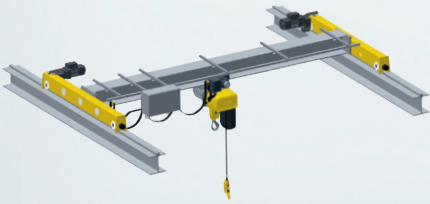

## Crane systems

GISKB steel crane construction kit for line-bound or all-round goods handling. GISKB aluminium crane system, slewing pillar and wall cranes for smooth handling of transport goods. Travelling cranes and slewing cranes made of steel profiles for heavier loads.

## Hoisting equipment

Over 50 years experience in the manufacture of electric chain hoists: robust, durable, reliable and highly resistant to wear. Simple maintenance. Various special versions for every application area. Wide range of accessories and options.

## Vacuum handling systems

GIS vacuum handling systems for the ergonomic and gentle handling of goods made of different materials like wood, glass, stone, metal or plastic. In combination with the appropriate crane system.

**GIS AG – the specialist for crane systems** Founding of the GIS AG in 1957 | With own subsidiary in Germany since 1966 | Development and production of electric chainhoists in Switzerland for over 50 years | Swiss manufacturer of complete crane systems incl. hoisting equipment and vacuum lifters | Certified to ISO 9001 since 1994 | Complete market services from project planning to installation, start-up and maintenance | International sales network with over 50 qualified partners worldwide

Swiss Lifting Solutions

Certified to ISO 9001

